

# Computer Engineering

## Meeting 1: Introduction

Developed by José R. de la Cruz

# What is Computer Engineering?

- **Computer Engineers** design, develop, implement and maintain computer systems applying the methods of Engineering.
- Computer Systems are those structures that rely on computer software and hardware to perform a specific task.
- Computer Engineering stems from Electrical Engineering, but has been a separate profession since 1982.

# What do Computer Engineers do?

- Engineer hardware
- Engineer software
- Engineer control systems
- Engineer CAD Applications
  - CAD: Computer Aided Design
- But, most important, as any Engineering discipline... **WE SOLVE PROBLEMS!**

# What do Computer Engineers do?

- Watch this short [video](#) created by ACES, the Association of Computer Engineering Students

# Computer Engineering Topics

Computer Engineers must understand and apply the following disciplines:

- Logic Circuits
- Electric circuits
- Electronics
- Programming
- Computer Architecture
- Microprocessors and microcontrollers

# Binary Logic

- Computer Engineers use binary logic in their everyday endeavors.
- Binary logic allows the Engineer to describe a process or situation using a simple mathematical model.
- In binary logic, states can have two values: TRUE or FALSE; 1 or 0.
- Three main operations: AND, OR & NOT.

# Binary Logic

- NOT is UNARY operator:
  - If  $X = 0$ , then  $\text{NOT } X = 1$  and vice-versa
  - Also represented as  $\neg X$  or  $X'$  or  $\overline{X}$
- AND (\*) is binary operator:

X	Y	$X * Y$
0	0	0
0	1	0
1	0	0
1	1	1

# Binary Logic

- OR (+) is binary operator:

X	Y	X + Y
0	0	0
0	1	1
1	0	1
1	1	1

- Binary operators allow for logic calculations in order to interpret and solve problems.
- Example:  $Z = X + (X * Y) + Y'$



# Number Systems

- Computer Engineers deal with many number systems, such as:
  - Binary: two values; 1 or 0
  - Octal: eight values; 0, 1, 2, 3, 4, 5, 6, 7
  - Decimal: ten values; 0, 1, 2, 3, 4, 5, 6, 7, 8, 9
  - Hexadecimal: sixteen values;
    - 0, 1, 2, 3, 4, 5, 6, 7, 8, 9, A, B, C, D, E, F
- Even the English alphabet can be interpreted as a 26 value number system!

# Number Systems

## Number system conversion examples

- Convert  $16_{10}$  to its binary equivalent

$$16_{10} = 1 \times 10 + 6 \times 1$$

$$16_{10} = 10000_2$$

- Convert  $16_{10}$  to its octal equivalent

$$16_{10} = 20_8$$

- Convert  $16_{10}$  to its hexadecimal equivalent

$$16_{10} = 10_{16}$$

# Number Systems

## Number system conversion examples

- Convert  $16_{16}$  to its binary equivalent

$$16_{16} = 00010110_2$$

- Convert  $16_{16}$  to its octal equivalent

$$16_{16} = 26_8$$

- Convert  $16_{16}$  to its decimal equivalent

$$16_{16} = 1 \times 16 + 6 \times 1$$

$$16_{16} = 22_{10}$$

# Number Systems

- Useful powers of 2
  - $2^0 = 1_{10}$
  - $2^1 = 2_{10}$
  - $2^2 = 4_{10}$
  - $2^3 = 8_{10}$
  - $2^4 = 16_{10}$
  - $2^5 = 32_{10}$
  - $2^6 = 64_{10}$
  - $2^7 = 128_{10}$
- Powers of 2
  - $2^8 = 256_{10}$
  - $2^9 = 512_{10}$
  - Kilo (KB) =  $2^{10} = 1,024_{10}$
  - Mega (MB) =  $2^{20} > 1.0 \times 10^6$
  - Giga (GB) =  $2^{30} > 1.0 \times 10^9$
  - Tera (TB) =  $2^{40} > 1.0 \times 10^{12}$
  - Peta (PB) =  $2^{50} > 1.0 \times 10^{15}$
  - Exa (EB) =  $2^{60} > 1.0 \times 10^{18}$

# Bits and Bytes

- In computer lingo we refer to bits and bytes
- A **bit**, or **binary digit**, holds or represents one of two values: 0 or 1
- A byte represents the basic storage structure for computer systems. It is an array, or collection, of 8 consecutive bits

<b>BIT#:</b>	7	6	5	4	3	2	1	0
	0	0	1	0	1	1	0	1
<b>VALUE:</b>	$2^7$	$2^6$	$2^5$	$2^4$	$2^3$	$2^2$	$2^1$	$2^0$
	128	64	32	16	8	4	2	1

# The Von Neumann Architecture

- The Von Neumann Architecture represents how modern computers are organized.

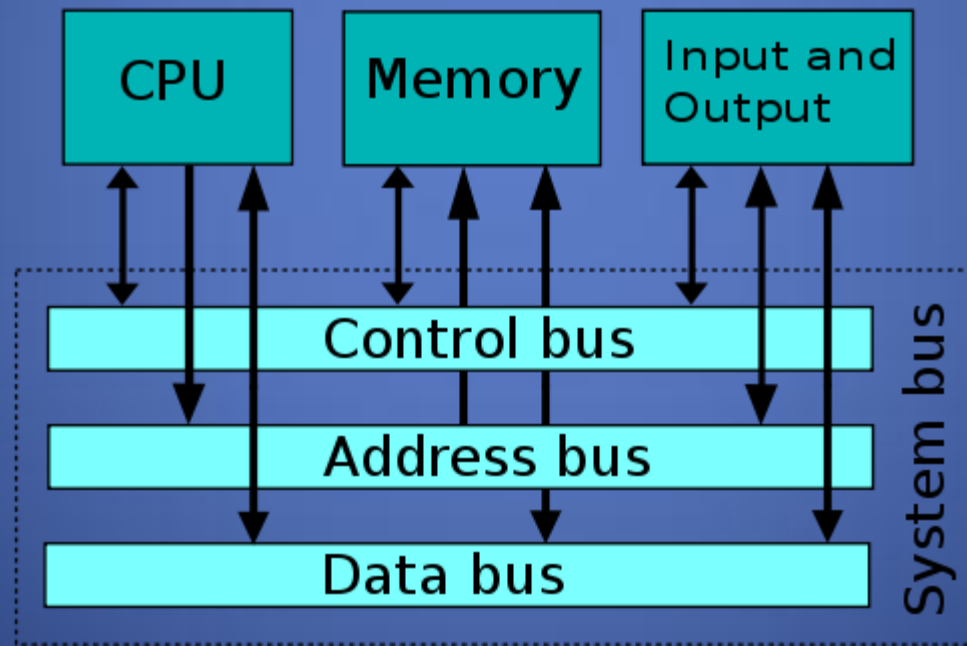

# The Von Neumann Architecture

- In the Von Neumann Architecture the CPU, or Central Processing Unit, is composed of four main parts:
  - ALU: Arithmetic Logic Unit, performs binary arithmetic operations and comparisons
  - Control Unit: Maintains 'order' by allowing access to buses
  - Registers: Hold the data and operations that are to be performed by the CPU
  - System, Data, and Control Buses: the cables that join all sections in order to transfer data

# The Von Neumann Architecture

- The other two main 'parts' of the architecture are:
  - Memory: Where programs and data are stored before reaching the CPU. Memory is managed by the operating system (OS).
  - Input/Output devices, or IO devices, also called peripherals. Examples are: monitors, printers, mouse, speakers, microphones, etc.
- The architecture is a layered one, in which the CPU 'communicates' with the outside world via the Memory.



# Module Project

- In order to get a “taste” for Computer Engineering, we will develop a simple project using a pseudo programming language, HTML
- HTML: Hypertext Markup Language
- HTML is the “language” of computer over the World Wide Web (WWW)
- You will be split in teams of three or four students each

# Module Project

- Using the basic HTML structures, your team will develop a 5 page Web site.
- You will implement this project by using HTML, CSS and JavaScript
- CSS: Cascading Style Sheets, used to format how the Web page is displayed
- JavaScript: Scripting language developed to enhance Web pages with dynamic activity

# Module Project

- The five page Web site will comprise:
  - A home or index page
  - An 'About' page where a picture and short description of each student will be posted
  - A 'Services' page where your team will detail the services you offer to the public
  - A 'Contact' page where you will inform the public how to contact your team
  - A 'Links' page where your team will showcase links to your favorite Web sites (HINT: Include Poli's Web site as one of them)
- The project will be presented in our next session, which is the last class meeting for the module

# Module Project

- One of your major resources for information on HTML, CSS and JavaScript is:
  - [www.w3schools.com](http://www.w3schools.com)
- Download Notepad++ to develop your HTML, CSS and JavaScript.
- All files created must be readable with Notepad or a regular text editor.
- DO NOT use Microsoft Office

# Module Project

- Remember, this project will be your main grading resource for this module.
- Get together with your team members and perform a brainstorming session.
- Implement the development guidelines presented in the course.
- It will be a fun learning experience!

# Next Meeting

- Since this is a hybrid course, our next meeting will be online.
- A learning module will be available in Blackboard
- You will be introduced to HTML, CSS and JavaScript.
- These topics discuss the tools you will use for your project.

# Questions

